

RECOMMENDED REFLOW TEMPERATURE PROFILE  
USIN LEAD-FREE SOLDER PASTE

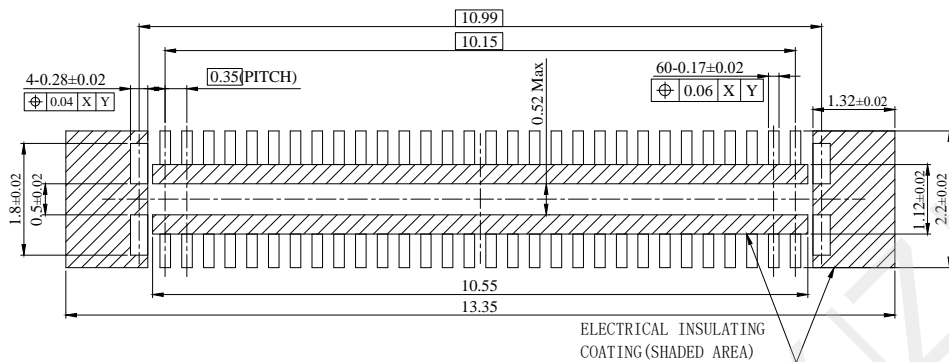

RECOMMENDED PCB LAYOUT

NOTES:

- 1.0 VOLTAGE: 50V AC/DC
- 2.0 CURRENT: 0.3A/SIGNAL CONTACT, 5A/POWER CONTACT
- 3.0 OPERATION TEMPERATURE: -40° C TO 85° C
- 4.0 CONTACT RESISTANCE (INITIAL): 70mΩ /SIGNAL CONTACT, 15mΩ /POWER CONTACT  
(AFTER TEST): 100mΩ /SIGNAL CONTACT, 20mΩ /POWER CONTACT
- 5.0 INSULATION RESISTANCE: 50MΩ MIN INITIAL
- 6.0 DIELECTIC WITHSTANDING VOLTAGE: 100V AC FOR ONE MINUTE
- 7.0 MATING: 50N Max  
UNMATING FORCE: (INITIAL) 6N Min; (AFTER TEST) 5N Min
- 8.0 DURABILITY: 30 CYCLES
- 9.0 IR REFLOW CYCLE: 2 CYCLES MAX.

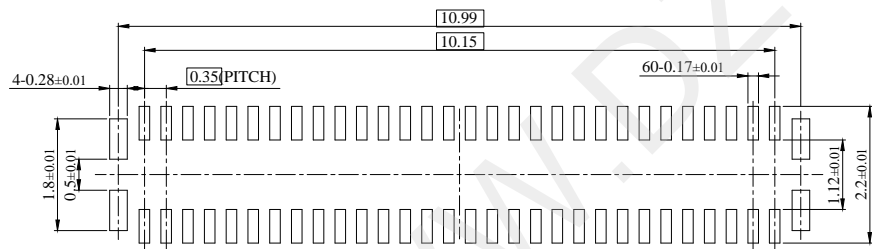

RECOMMENDED METAL DIMENSIONS (THICKNESS: 0.08 mm)

3	POWER CONTACT	COPPER ALLOY, Au4u <sup>2</sup> Min ON CONTACT AREA, Au2u <sup>2</sup> Min ON SOLDER AREA, Ni 50u <sup>2</sup> Min ALL OVER	6	REEL	PLASTIC
2	SIGNAL CONTACT	COPPER ALLOY, Au4u <sup>2</sup> Min ON CONTACT AREA, Au2u <sup>2</sup> Min ON SOLDER AREA, Ni 50u <sup>2</sup> Min ALL OVER	5	COVER TAPE	PLYESTER
1	HOUSING	LCP, BLACK, UL 94 V-0	4	EMBOSSED CARRIER TAPE	PS
NO.	PART NAME	DESCRIPTION, REMARKS	NO.	PART NAME	DESCRIPTION, REMARKS



深圳市华宇创精密电子有限公司

<b>TOLERANCE:</b> X.X ±0.30 X.XX ±0.25 X.XXX ±0.15 X.' ±2' X.X' ±0.5'	DRAWN BY :	DATE :	PART NAME:
	陈一鸣	2014-02-23	0.35PH 单槽BTB 公座 60P
 UNIT: mm [inch] SCALE:1:1 SIZE: A4	CHECKED BY:	DATE :	PART NO.
	马跃	2014-02-23	HYC61M-BTB2X30-049
	APPROVED BY:	DATE :	DRAW NO:
	邱敏	2014-02-23	HYC-2511201629
			SHEET NO. 1 OF 1

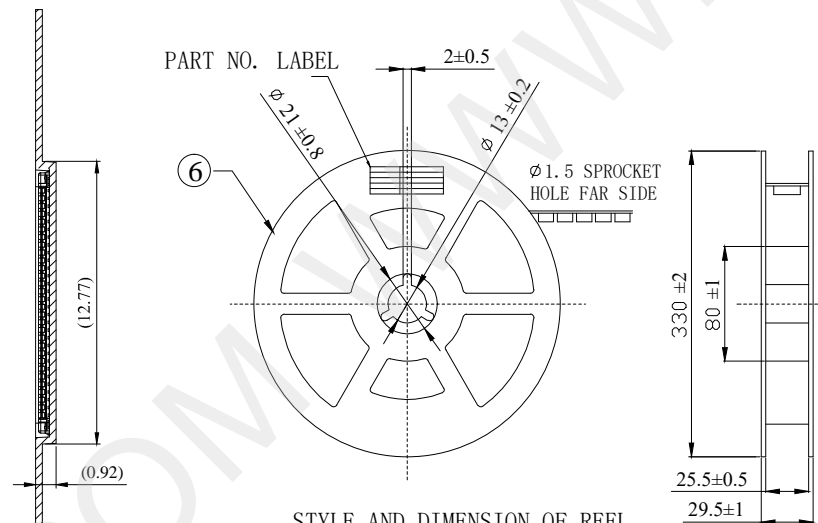
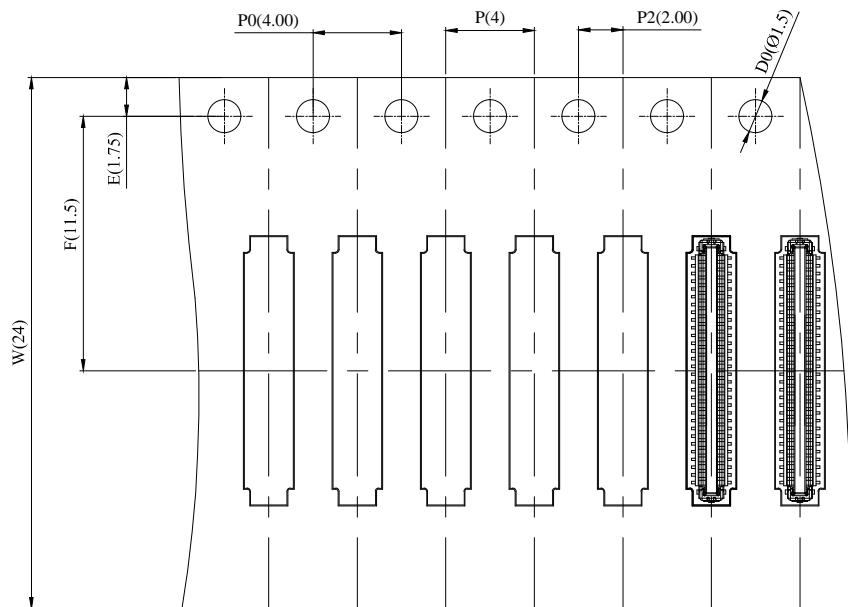

STYLE AND DIMENSION OF REEL

PER REEL 15000 CONNECTORS

DIRECTION OF UNREELING

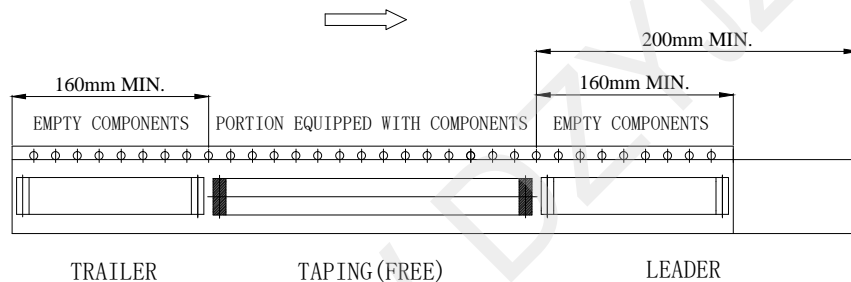

深圳市华宇创精密电子有限公司

TOLERANCE: X.X ±0.30 X.XX ±0.25 X.XXX ±0.15 X' ±2' X.X' ±0.5'	DRAWN BY : 陈一鸣	DATE : 2014-02-23	PART NAME: 包装图	
	CHECKED BY: 马跃	DATE : 2014-02-23	PART NO.	
UNIT: mm [inch] SCALE:1:1 SIZE: A4	APPROVED BY: 邱敏	DATE : 2014-02-23	MOLD NO.	
			DRAW NO:	
			SHEET NO.	1 OF 1

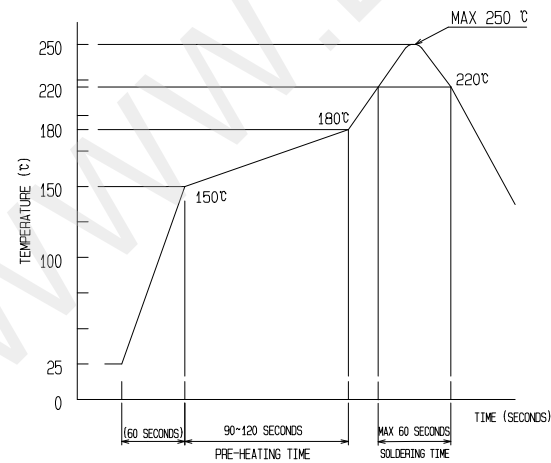
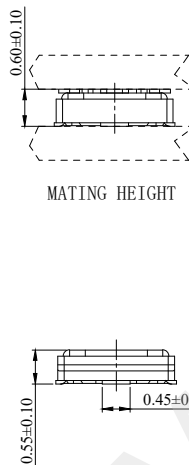
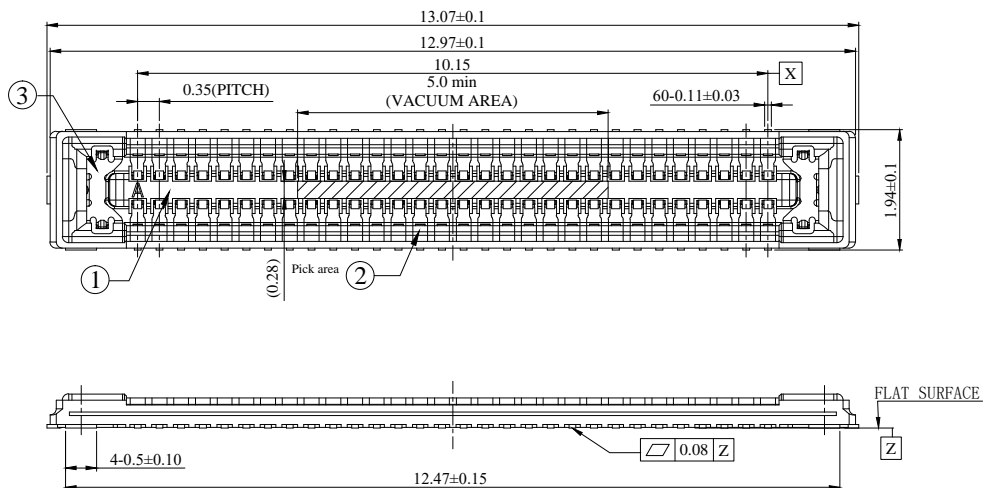

RECOMMENDED REFLOW TEMPERATURE PROFILE  
USIN LEAD-FREE SOLDER PASTE

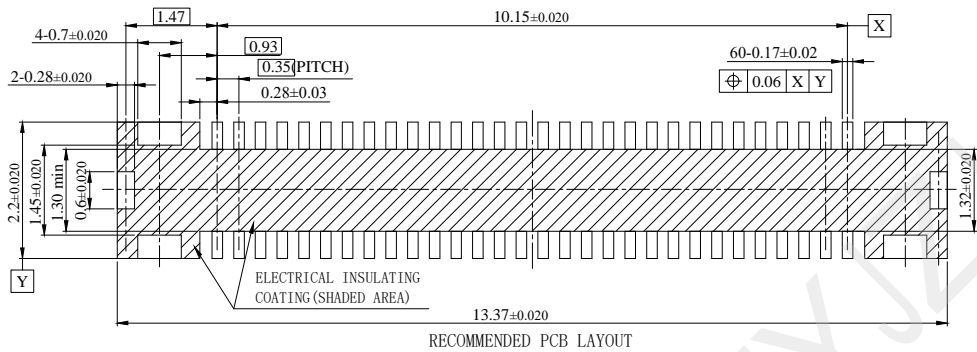

RECOMMENDED PCB LAYOUT

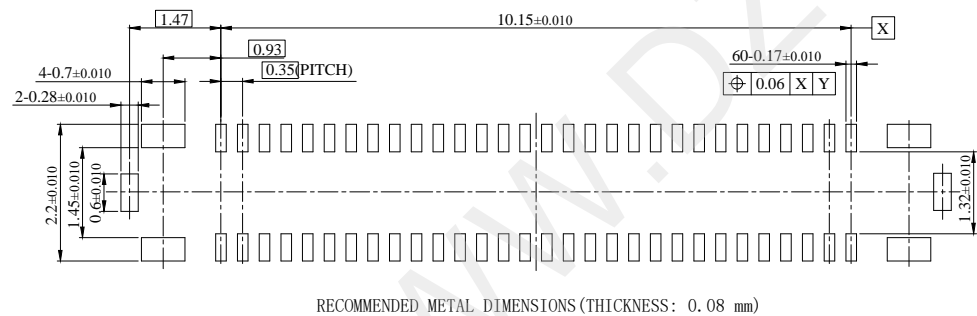

RECOMMENDED METAL DIMENSIONS (THICKNESS: 0.08 mm)

NOTES:

- 1.0 VOLTAGE: 50V AC/DC
- 2.0 CURRENT: 0.3A/SIGNAL CONTACT, 5A/POWER CONTACT
- 3.0 OPERATION TEMPERATURE: -40° C TO 85° C
- 4.0 CONTACT RESISTANCE (INITIAL): 70mΩ /SIGNAL CONTACT, 15mΩ /POWER CONTACT  
(AFTER TEST): 100mΩ /SIGNAL CONTACT, 20mΩ /POWER CONTACT
- 5.0 INSULATION RESISTANCE: 50MΩ MIN INITIAL
- 6.0 DIELECTRIC WITHSTANDING VOLTAGE: 100V AC FOR ONE MINUTE
- 7.0 MATING: 50N Max  
UNMATING FORCE: (INITIAL) 6N Min; (AFTER TEST) 5N Min
- 8.0 DURABILITY: 30 CYCLES
- 9.0 IR REFLOW CYCLE: 2 CYCLES MAX.

3	POWER CONTACT	COPPER ALLOY, Au60 <sup>μ</sup> Min ON CONTACT AREA, Au20 <sup>μ</sup> Min ON SOLDER AREA, Ni 50μ <sup>μ</sup> Min ALL OVER	6	REEL	PLASTIC
2	SIGNAL CONTACT	COPPER ALLOY, Au60 <sup>μ</sup> Min ON CONTACT AREA, Au20 <sup>μ</sup> Min ON SOLDER AREA, Ni 50μ <sup>μ</sup> Min ALL OVER	5	COVER TAPE	PLVYESTER
1	HOUSING	LCP, BLACK, UL 94 V-0	4	EMBOSSED CARRIER TAPE	PS
NO.	PART NAME	DESCRIPTION , REMARKS	NO.	PART NAME	DESCRIPTION , REMARKS



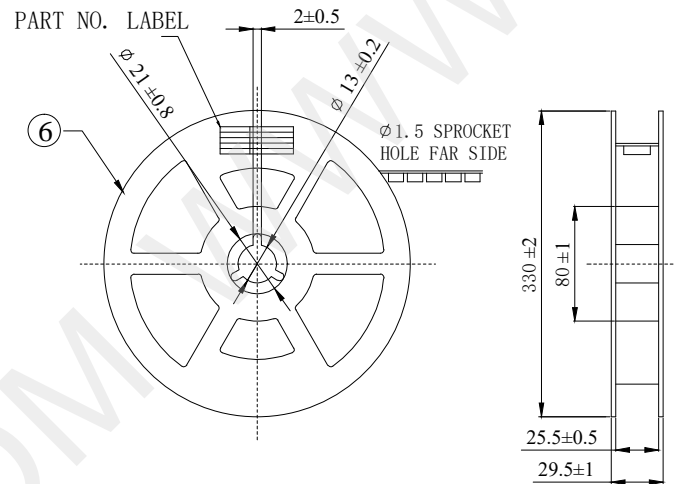
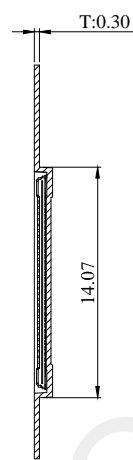
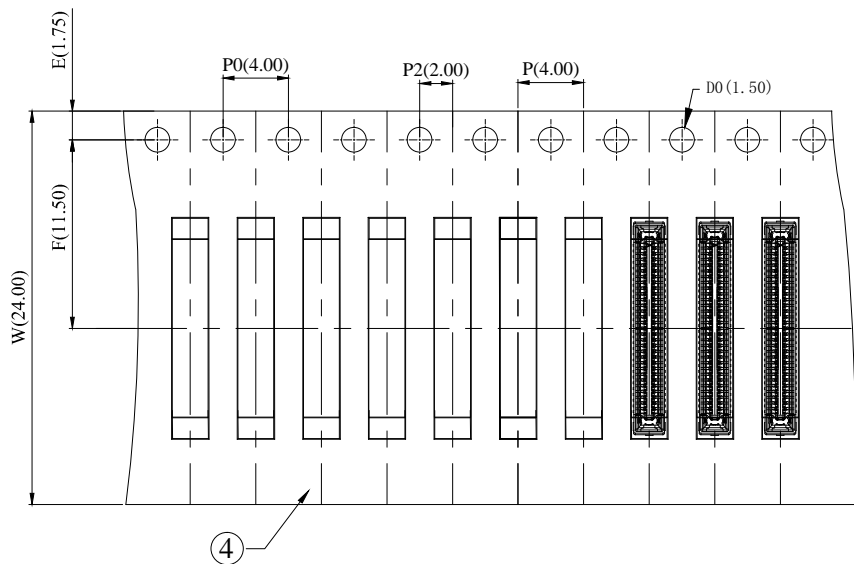

深圳市华宇创精密电子有限公司

<b>TOLERANCE:</b> X.X ±0.30 X.XX ±0.25 X.XXX ±0.15 X.' ±2' X.X' ±0.5'	DRAWN BY :	DATE :	PART NAME:
	陈一鸣	2014-02-23	0.35PH 单槽BTB 母座 60P
	CHECKED BY:	DATE :	PART NO.
	马跃	2014-02-23	HYC61F-BTB2X30-055
UNIT: mm [inch] SCALE:1:1 SIZE: A4	APPROVED BY:	DATE :	DRAW NO:
	邱敏	2014-02-23	HYC-2511201633
			SHEET NO. 1 OF 1

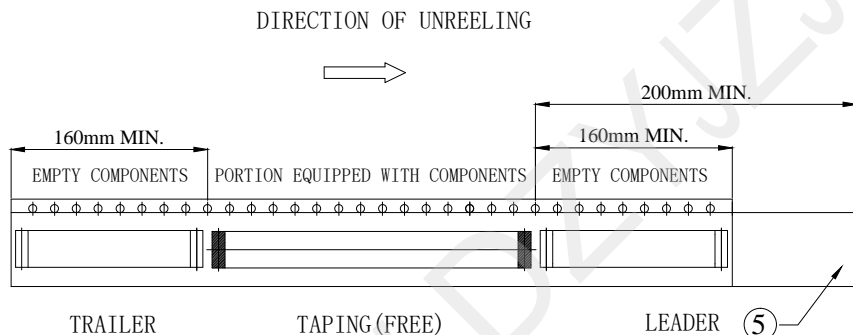

STYLE AND DIMENSION OF REEL  
PER REEL 15000 CONNECTORS



 <b>深圳市华宇创精密电子有限公司</b>			
<b>TOLERANCE:</b> X.X ±0.30 X.XX ±0.25 X.XXX ±0.15 X.' ±2'    X.X' ±0.5'	<b>DRAWN BY :</b> 陈一鸣	<b>DATE :</b> 2014-02-23	<b>PART NAME:</b> 包装图
	<b>CHECKED BY:</b> 马跃	<b>DATE :</b> 2014-02-23	<b>PART NO.</b> 
<b>UNIT:</b> mm [inch] <b>SCALE:</b> 1:1 <b>SIZE:</b> A4	<b>APPROVED BY:</b> 邱敏	<b>DATE :</b> 2014-02-23	<b>MOLD NO.</b> 
			<b>DRAW NO:</b> 
			<b>SHEET NO.</b> 1 OF 1